



# Door Pocket Set

Installation Instructions  
Part Number RT27071



FIND US ONLINE



FACEBOOK

INSTAGRAM

YOUTUBE

WEBSITE



## Tools Needed

-  Plastic clip removal tool
-  90° pick
-  Flat head Screwdriver
-  T25 torx bit
-  T30 torx bit
-  Ratchet
-  5/16 Drill bit
-  Drill
-  10mm socket
-  Socket Extension

## Included in Box

- (2) Front Pockets
- (2) Rear Pockets
- (33) Large Trim Nuts
- (33) Small Trim Nuts

# Installation Instructions

Its ok to be alarmed by the sight of your useless saggy net. Today is the last day you will be greeted by this disappointment.

If there are any questions about the proper installation of OEM components or torque specs, refer to your owner's manual or a dealer's repair manual

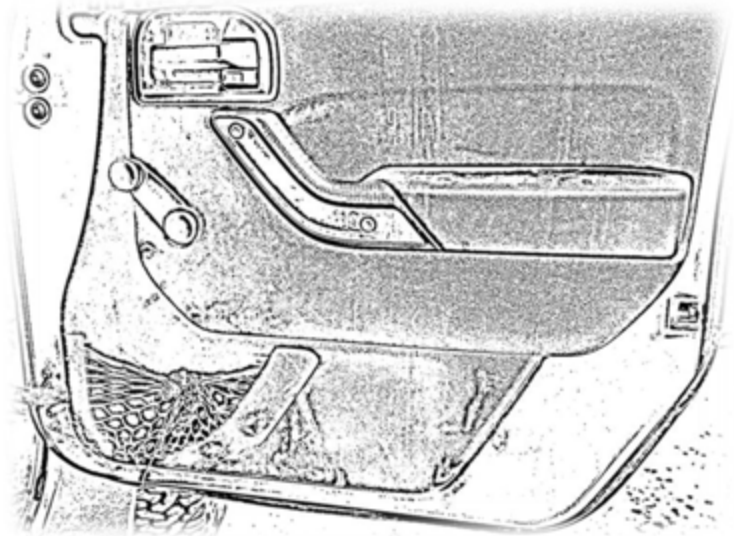

Inside the door handle is a small plastic closeout. Use a 90° pick or small flat head screwdriver to gently pry the closeout from the handle without scratching or deforming it.

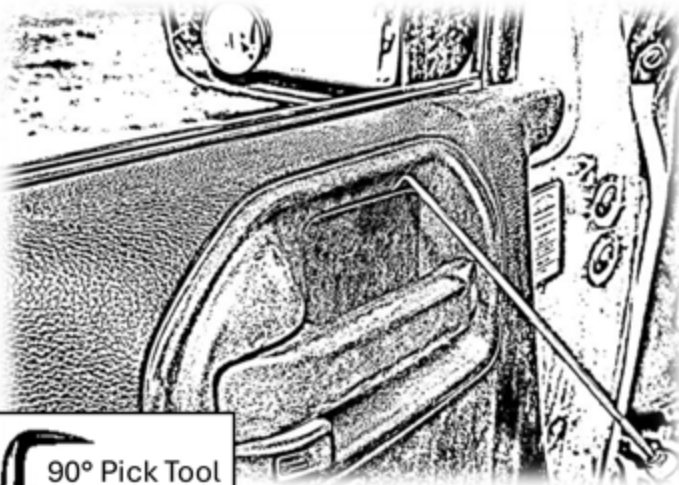

 90° Pick Tool

Do not try to remove the large Allen head screws from the decorative cover on the door grab handle, they are for decoration only. Gently pry the decorative cover from the door handle by sliding a plastic clip removal tool under the decorative cover. Slowly work around the cover until it is fully released from the handle.

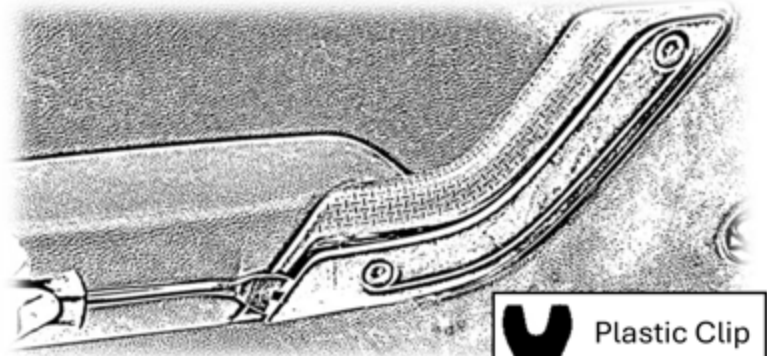

 Plastic Clip Removal Tool

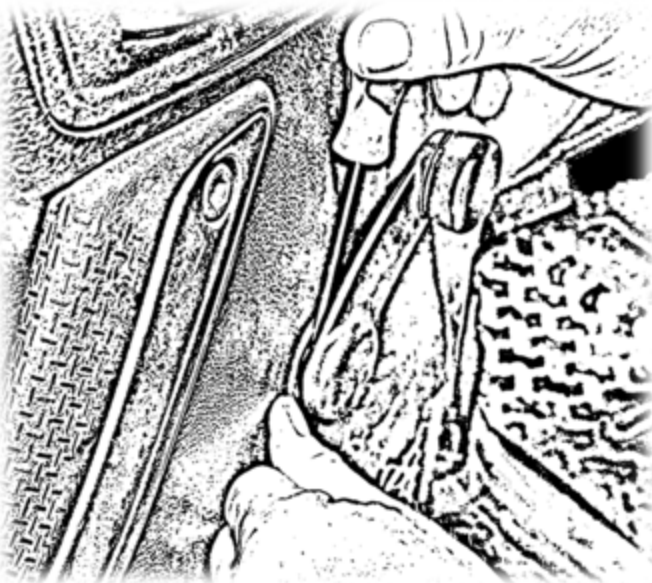

If you have manual windows, press on the door panel to create a gap between the crank handle and the panel. Use a small flat head screwdriver, 90° pick, or crank handle clip removal tool to release the clip from the back of the crank handle. If you have power windows, you will not have the crank handle but will likely have a lock switch that will need to be disconnected once the door panel is removed from the door.



\*Place the screws you remove in a safe place

Both front and rear doors have (5) T25 screws. Remove the T25 screws with a T25 Torx bit and a ratchet or screwdriver. See the diagram below for the screw locations

Rear Door Screw Locations

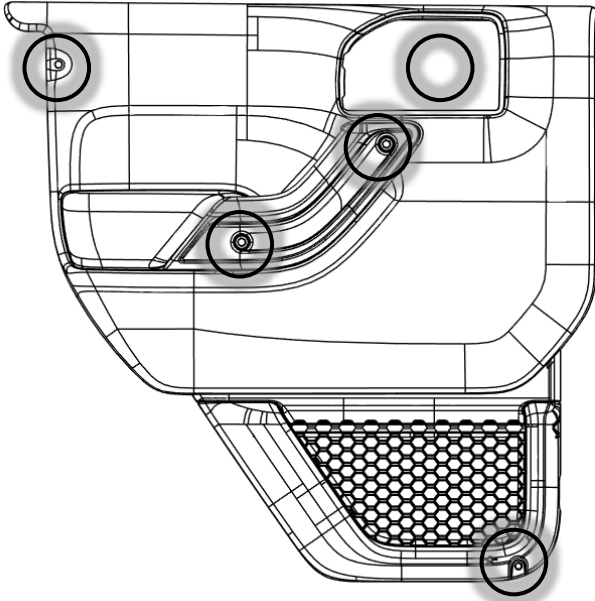

Front Door Screw Locations

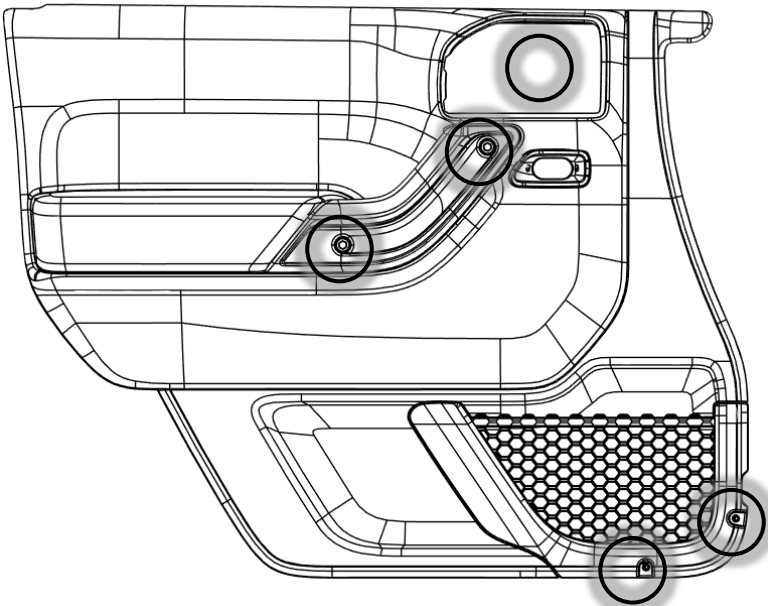

The release handle trim can now be removed. Gently pry around the perimeter of the handle trim using the plastic clip removal tool. Remove the trim piece by sliding it over the release handle, you may need to open the handle partially to have clearance for removing the trim.

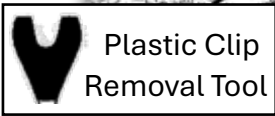
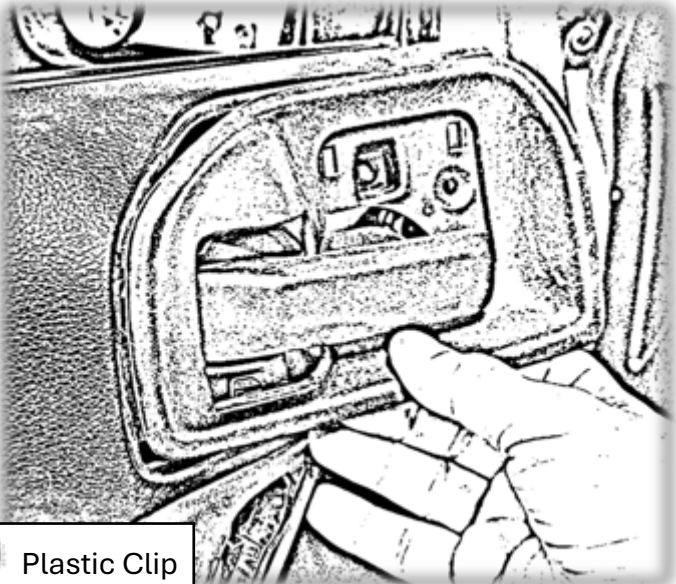

The front door panel has (10) trim clips fastening it to the metal door and the rear door panel has (9). Pull out on the plastic panel and slide the clip removal tool behind it. Locate the tool on each clip securely and use the pry tool to pop the clip off the metal door. You may place a piece of cloth, paper or cardboard between the tool and the metal door to protect the paint on the door. Do not try to remove the plastic door panel by prying on it anywhere other than on the clips themselves. The clip locations are shown below:

Rear Door Clip Locations

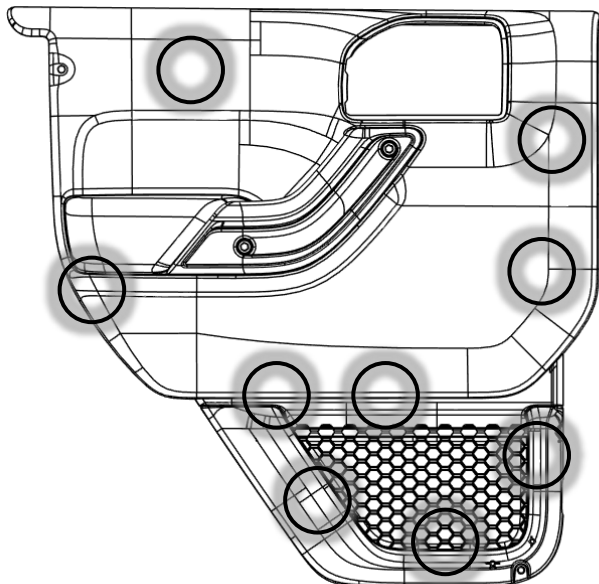

Front Door Clip Locations

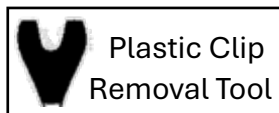
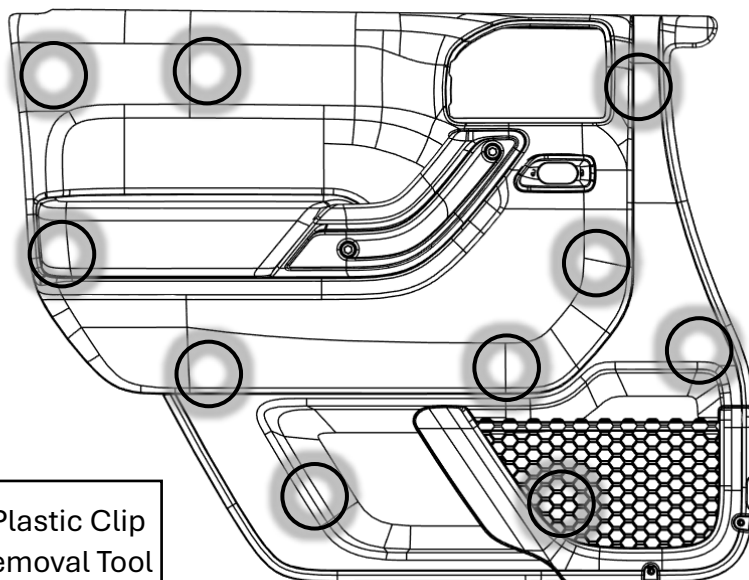

The plastic door panel hooks into the top seal by the window. Remove the panel by wiggling it while lifting to unseat it from the seal. The window seal may come out with the door panel. If this happens, just snap it back into the window channel.

Remove the door panel from the jeep and set it on a table. Place something soft below the panel to protect the front of it from scratches.

Use a drill bit to remove the plastic welds that hold on the utterly useless net. Align you drill bit with the hole in the center of each weld. You do not need to drill very far to disconnect the net, but if you accidentally punch all the way through it, that is OK the only thing you are damaging is the pathetic net that you are in process of replacing.

Drill out all welds, (15) on front door, (16) on rear door.

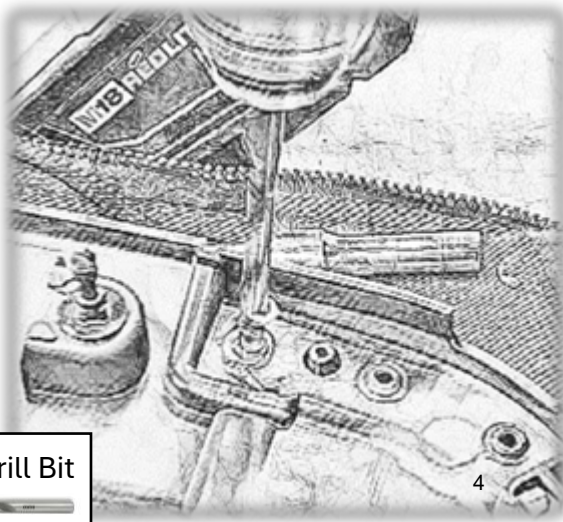

5/16 Drill Bit

Place the OEM Plus door pocket on the table face down and then place the door panel on top of it.

Align the posts on the back of the door pocket to the holes you drilled in the door panel. You may need to deform the door or pocket slightly to initially get all of the holes to line up.

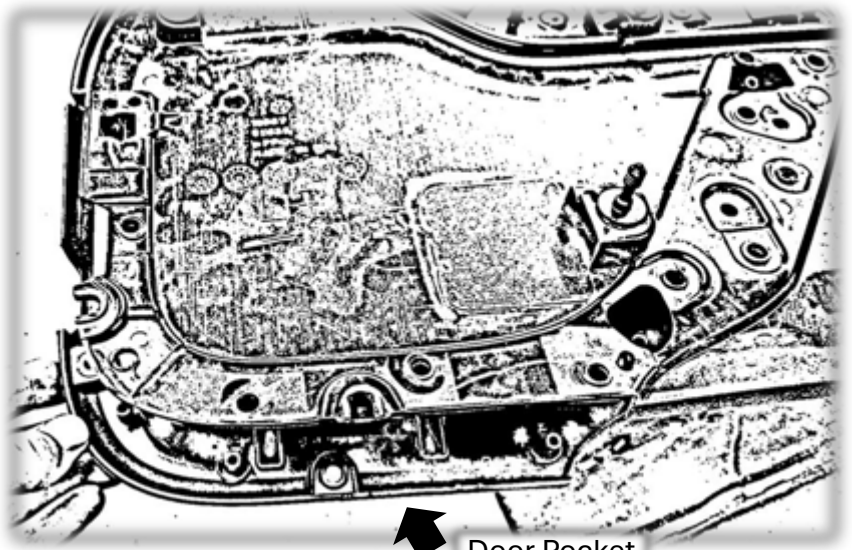

Press the provided trim nuts over the posts on the door pocket with a 10mm socket, using a socket extension as a handle. Press down firmly while supporting the front of the pocket with your other hand.

Do this for all posts. (15) on front door, (16) on rear door

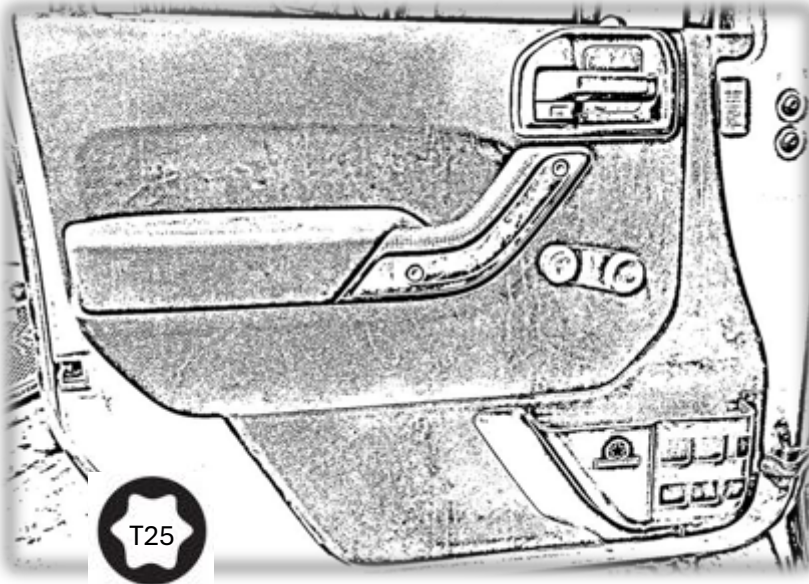
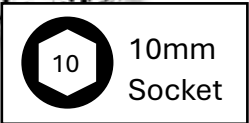
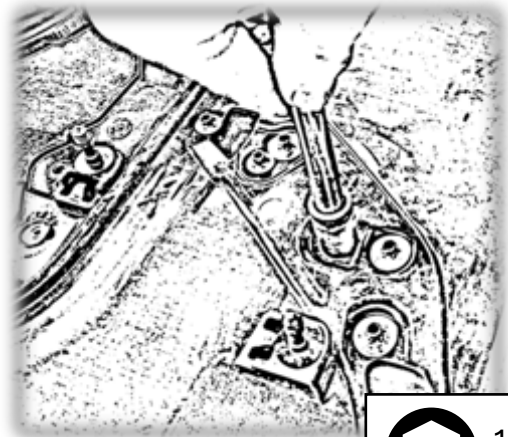

Re-install the door panel by first connecting the wire harness (if you have one). Hook the top of the door panel into the window seal and swing it down aligning the pins with their holes in the sheet metal. Press on the face of the door panel near each pin until you hear a click sound. You may have to press hard or swiftly to seat the pins. Refer to the location of the pins on the previous page.

Slide the handle trim piece back over the release handle. Reinstall the (5) T25 screws, be careful not to over torque them.

Snap in the decorative cover on the grab handle and the closeout on the release handle. If you have manual windows, reinstall the clip into the crank handle and snap the handle back onto its post.

Throw away the ridiculous net and repeat this process for the other side.

